

See discussions, stats, and author profiles for this publication at: <https://www.researchgate.net/publication/235956667>

INTEGRAL HAZARD MANAGEMENT USING A UNIFIED SOFTWARE ENVIRONMENT

Conference Paper · April 2012

CITATIONS

11

READS

1,001

12 authors, including:



Marc Christen

WSL Institute for Snow and Avalanche Research SLF

78 PUBLICATIONS 1,989 CITATIONS

[SEE PROFILE](#)



Yves Bühler

WSL Institute for Snow and Avalanche Research SLF

148 PUBLICATIONS 2,216 CITATIONS

[SEE PROFILE](#)



Perry Bartelt

WSL Institute for Snow and Avalanche Research SLF

194 PUBLICATIONS 6,252 CITATIONS

[SEE PROFILE](#)



Remco Leine

Universität Stuttgart

128 PUBLICATIONS 4,136 CITATIONS

[SEE PROFILE](#)

Some of the authors of this publication are also working on these related projects:



bDFA – beyond dense flow avalanches. Quantifying the destructive reach of snow avalanches beyond the dense flow regime [View project](#)



Untersuchung von Aufprallprozessen [View project](#)

INTEGRAL HAZARD MANAGEMENT USING A UNIFIED SOFTWARE ENVIRONMENT

NUMERICAL SIMULATION TOOL “RAMMS” FOR GRAVITATIONAL NATURAL HAZARDS

Marc Christen¹, Yves Bühler¹, Perry Bartelt¹, Remco Leine², James Glover¹, Adrian Schweizer²,
Christoph Graf³, Brian W. McArdell³, Werner Gerber³, Yolanda Deubelbeiss³, Thomas Feistl¹
and Axel Volkwein³

ABSTRACT

Avalanches, debris flows and rockfalls are gravitationally driven natural hazards. Hazard mitigation experts are confronted with the problem of predicting the trajectories, runout distances and velocities of such fast moving processes in mountain terrain. Numerical simulation is difficult because the dynamical behaviour of each process is governed by different flows and impact mechanics in interaction with terrain features. Here we report on the development of a software package which is intended to assist practitioners and researchers to simulate these gravitationally-driven natural hazards. The software includes four different process modules to predict (1) snow avalanches, (2) debris flows, (3) hillslope debris flows and (4) falling rocks. The process modules are linked together by a common user interface that simplifies the specification of the three-dimensional mountain terrain model, detailing the starting conditions and the model parameters. The tool facilitates a direct comparison of the influence of mitigation measures on several different processes (e.g. the influence of avalanche retention dams on avalanche runout as well as debris flow runout and rockfall). The tool interactively displays the results of the process intensity to support the generation of hazard intensity maps and the influence of mitigation structures on changes in intensity.

Keywords: snow avalanche, debris flow, rockslide, landslide, rockfall, numerical models, simulations, hazards maps, RAMMS

INTRODUCTION

In the field of natural hazards there is a strong need for process models that simulate the runout behaviour of avalanches, debris flows and rockfalls. Such models are often applied to evaluate the interaction of a given process with mitigation measures, such as forests or deflecting dams as well as for hazard mapping. Traditionally, different software tools are used for each process.

In this paper we briefly describe a unified software package to simulate avalanches (Fig. 2), debris flows (Fig. 3), hillslope debris flows (Fig. 4) and rockfalls (Fig. 5). The software package RAMMS (Rapid Mass MovementS) unites the four process modules (Fig. 1) with a user-friendly graphical interface. In the following, we discuss the software engineering challenges of integrating different process models in a single tool. The models have been tested and calibrated using the WSL's real scale test sites (Ammann, 1999; Gerber, 2001; McArdell et al., 2007; Glover et al., 2010; Bugnion et al., 2011) and data from accurately documented case studies (e.g. Bartelt et al. 2012, Christen et al.

¹ WSL-Institute for Snow and Avalanche Research SLF, Davos, Switzerland (email: christen@slf.ch)

² Swiss Fed. Institute of Technology ETHZ, Zurich, Switzerland

³ Swiss Fed. Research Institute WSL, Zuercherstr. 111, 8903 Birmensdorf, Switzerland

2010a). By integrating different physical models in one tool, it is possible for engineering offices to apply a single tool to treat different natural hazards. The common interface allows for a comprehensive evaluation of mitigation measures to support integral risk management.

UNIFIED MODELLING OF NATURAL HAZARDS

The unified modelling of different natural hazards is a useful, but difficult software engineering task. Software developers are confronted with challenges at the centre of natural hazards research.

Specification of initial conditions

A flexible and accurate specification of model initial conditions is necessary to investigate different hazard scenarios. However, each process has unique starting conditions. For snow avalanches the location and dimensions of one or more release volumes (area and fracture height) are required; for debris flows the bulk mass flux and a given location in the torrent is usually more useful than the specification of a release block. To calculate rockfall trajectories requires the specification of the position, orientation and initial potential or kinetic energy (fall heights or initial rotational or translational velocity) of the rock. Often the specification of initial conditions is prescribed by calculation and hazard guidelines, which may vary from country to country. Therefore, a software system for different natural hazards must allow a wide range of different input possibilities, depending on the particular process and problem (Fig. 1).

Digital elevation models DEM

A prerequisite for a correct numerical calculation is an accurate digital elevation model (Fig. 1). The resolution of the digital elevation models is often prescribed by government mapping agencies. High accuracy elevation models (on the order of 0.5 m) may be obtained from aerial laser scanning or digital photogrammetry (Bühler et al. 2012), especially in most European countries. Bühler et al., 2011 demonstrated that elevation models with poor spatial resolution (on the order of 25 m and more) may miss important terrain features while too accurate elevation models (on the order of 1 m or less) may lead to extensive computation times and even incorrect simulation results. The optimal spatial resolution of the elevation model is, again, both process and case dependent. For example, in snow avalanche studies a 5 m calculation resolution is often selected (even if the elevation model is more accurate) since the snow cover smoothes high frequency terrain undulations (Bartelt et al., 2012). The software system must therefore allow digital elevation models to be resampled to the appropriate resolution for the process being modelled.

Process models and model parameters

The selection of model parameters remains one of the fundamental challenges for numerical calculations in natural hazards. Each process model requires sets of well-tested model parameters to simulate events with statistical confidence. Process models that are physically based, i.e. computer models that are controlled by parameters that can be mapped directly to terrain characteristics and material properties are of great utility. This is seldom the case in natural hazards research where snow avalanche (Gruber and Bartelt, 2007), debris flow (Berger et al. 2011) and rockfall models (Volkwein et al. 2011) all require few, but empirical parameters that vary from case to case. This severely limits the application range of numerical software. It is obvious that a numerical model cannot have too many parameters, as this severely limits user confidence and increases the possibility of applying incorrect values. Continuity of models is another important factor in engineering practice; otherwise simulations must be recalculated, causing uncertainty and perhaps legal problems. See contribution of Jörg et al. (2012) in this volume.

The numerical solution

Today’s computational capabilities and advances in software engineering are changing how natural hazard problems are solved. However, many different applications require time and resources to learn and to efficiently use. Hastily performed-simulations without appropriate sensitivity analyses and parameter studies are not uncommon in practice, and this may be partially due to the fact that many different programs have to be mastered to efficiently perform an analysis. If it were possible to use the same software package to analyse different natural hazards, this effort could be minimized and – more importantly – the risk of mistakes due to an insufficient knowledge of different software products could be reduced.

Visualization

Engineers use a variety of visualization methods to depict hazard such as maps, photos, 2d and 3d simulation results, XY-plots, terrain profiles and animations (Fig. 1). Numerical simulation software must be able to import and export georeferenced information and overlay simulation results. This is essential for reporting, presenting results to local and federal authorities, as well as the simple interpretation of simulation results by experts. The visualization of computational results makes the numerical calculations transparent and easier to follow by non-numerical specialists. The software must be able to export the results to other tools such as ArcGIS to further process the data.

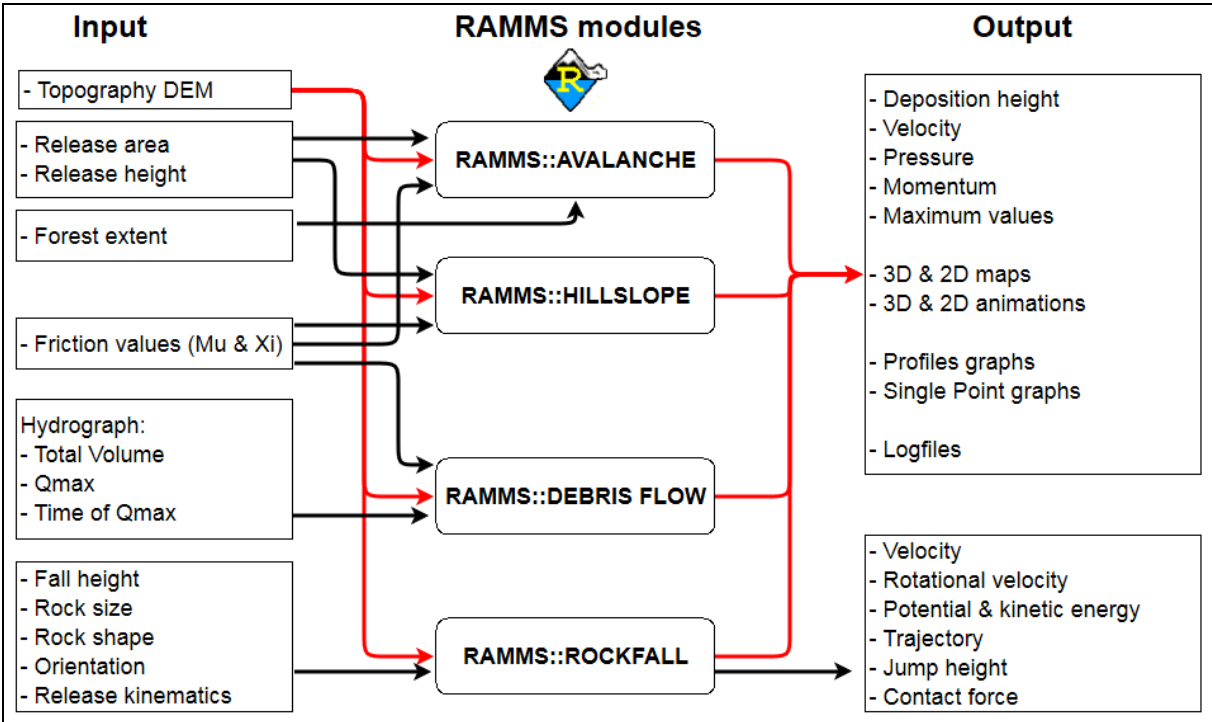

Fig. 1: RAMMS project workflow showing both the specific and unified input and output features for the unified RAMMS modules.

RAMMS::AVALANCHE

The RAMMS::Avalanche module solves two-dimensional depth-averaged mass and momentum equations on three-dimensional terrain using both first and second-order finite volume methods, see Fig. 2 (Christen et al., 2010b). The model predicts avalanche velocities and flow heights. Initial conditions for avalanche release are specified by defining a slab area with a fixed fracture height (Fig. 2). It is possible to define several slab areas with different fracture heights to account for variable release conditions, including wind blown snow near mountain crests. In its most basic form, the RAMMS::Avalanche module employs the well-calibrated Voellmy friction model (Voellmy, 1955) containing two parameters: the Coulomb friction (μ) and the velocity squared dependent turbulent

friction (ξ). These parameters can be selected as constant for the entire problem domain, or can vary spatially to account for variations in terrain characteristics, roughness or vegetation (Gruber and Bartelt, 2007). Calculations are automatically stopped when the total mass flux decreases to a value below a fraction of the maximum mass flux.

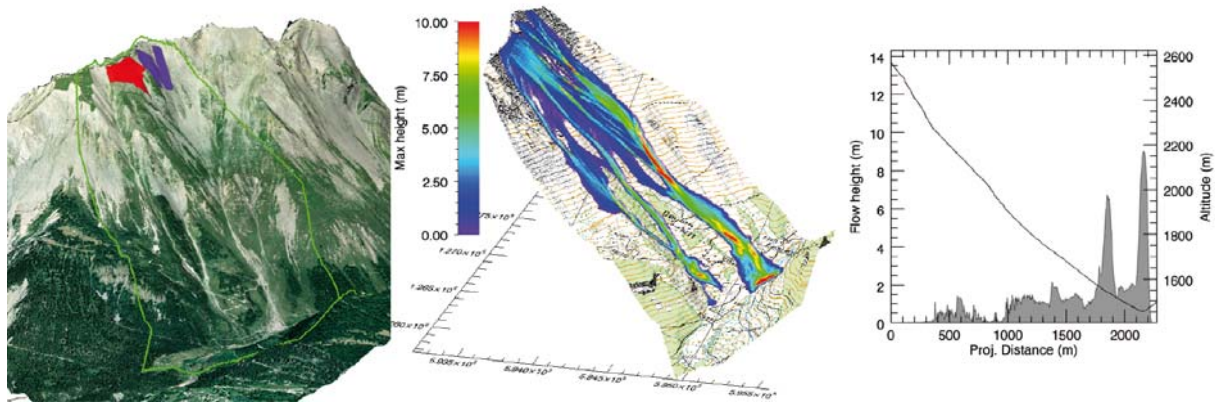

Fig. 2: RAMMS::AVALANCHE – release area and situation overview (left) and output of avalanche simulation in 3D (middle) and along an avalanche path (right) in Vallée de la Sionne, Switzerland.

Swiss guideline suggestions for friction parameters (based on extensive model calibration) are also available (Salm, 1990). These values correspond to extreme, fast moving, dry-flowing avalanches that are typically accompanied by a powder cloud. The parameters implicitly account for avalanche size and therefore snow cover entrainment does not have to be explicitly included in the model calculations. Impact pressures are derived from kinetic energy densities under the assumption of a constant flow density. As dry-flowing avalanches represent the fastest and far reaching avalanche form, this generic model is well-suited for hazard mapping and practical application (Christen et al., 2010a).

However, the RAMMS::Avalanche module is a continual work in progress. New features are being developed to account for different avalanche sizes, starting conditions and flow forms keeping up to date with recent scientific findings.

One recent result is in the inclusion of a description of the fluctuation energy of the snow granules (Bartelt et al., 2012) – which greatly effects flow friction, producing flow regime transitions (such as solid-like tails and dilute flow fronts). A variable density avalanche model is now being tested that should help reproduce avalanche impact pressures more accurately. Because the production of fluctuation energy is mass dependent, entrainment processes will be included in model updates.

Many users are confronted with wet snow avalanche problems and a special wet snow avalanche model should be ready for testing in late 2012. This model will account for high snow temperatures and predict the free water content in the flow, providing the necessary state variables to model snow gliding and levee formation. Users are also interested in modelling small, frequent avalanches. In this area we are working on the specification of initial conditions (snowpack structure and collapse) as well as defining appropriate digital elevation models. Considerable calibration of small avalanche events is underway.

Finally, the physical boundary conditions for air blowout from the granular core are being formulated. This will allow the coupling of RAMMS::AVALANCHE to a new powder snow avalanche code which can be used to model mixed flowing/powder avalanches in the near future.

RAMMS::DEBRIS FLOW

The RAMMS::DEBRIS FLOW module was developed to simulate the runout of debris flows in complex terrain (Graf and McArdell, 2008; Graf and McArdell, 2011). The module can also be used to calculate the impact pressures and flow heights for use in the dimensioning of engineering mitigation

measures. The core of the program is a second-order numerical solution of the depth-averaged equations of motion for granular flows. Similar to the avalanche module, model results are calculated and visualized on three-dimensional digital elevation models. Users can choose between single or multiple block-release areas or a hydrograph input can be defined allowing the user to specify the discharge and velocity as a function of time (see below). RAMMS::DEBRIS FLOW neglects erosion and entrainment at the moment (Berger et al. 2011, Schürch et al 2011); however “bulking” algorithms are in development. An example of the performance of RAMMS::DEBRIS FLOW can be found in Scheuner et al. (2011) and Berger et al. (2012).

The model uses the two-parameter Voellmy-fluid model (Voellmy, 1955) to describe the rheology of the flowing debris, which has been shown by others to be useful for modelling debris-flow runout. The Voellmy model describes the friction behaviour of the flow process based on the Coulomb friction (μ) and the velocity squared dependent turbulent friction (ξ). To calibrate the Voellmy model, users generally simulate well-documented historical events and determine the best-fit parameter sets that can be used in subsequent analyses. The ability to modify the topography to include deposits from a previously-modelled surge allows users to evaluate the influence of multiple surges on the runout of debris flows.

Regarding the input hydrograph (Fig. 3), flow discharge based on measurements or estimates allows users to reduce the calculation time (because the computational domain area can be made smaller) or increase the grid resolution by starting the model at a location well-downslope from the initiation zone, e.g. at the apex of the fan (Fig. 3).

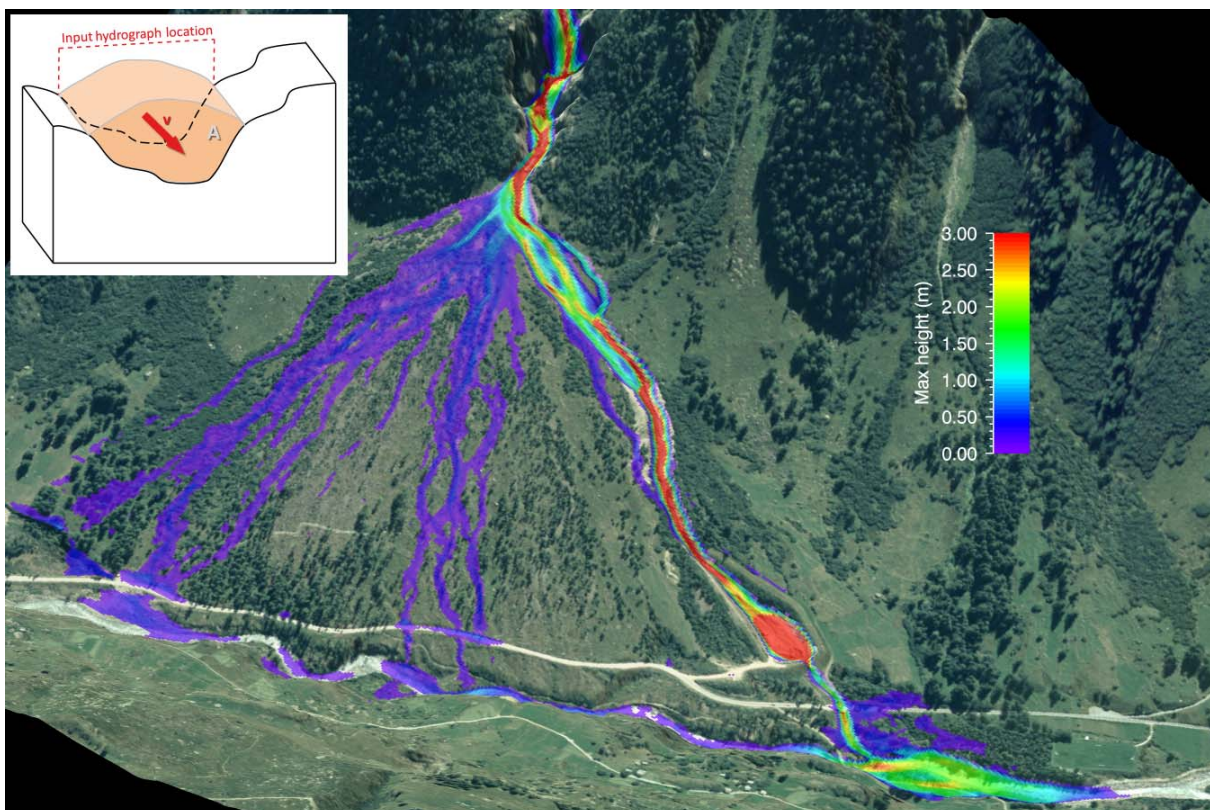

Fig. 3: RAMMS::DEBRIS FLOW simulation, Stampbach, Switzerland. Hydrograph (upper left): discharge $Q = A \cdot v$ (m^3/s) where A (m^2) is the cross-sectional area of the debris flow and v (m/s) the inflow velocity.

RAMMS::HILLSLOPE

Landslides move downslope in many different ways (Varnes, 1978). In addition to small slumps and slides, landslides can evolve into rapidly travelling flows, which exhibit characteristics of debris flows on unchanneled or only weakly channeled hillslopes. Hillslope debris flows are a problem in lots

of countries, and many of their unique geomorphic properties resulted in the adaption of the debris flow model to be optimized for modelling the runout of hillslope debris flows.

The geomorphic heterogeneity of rapid shallow landslides such as hillslope debris flows is larger than observed in channelized debris flows, however many of these flows can be successfully modelled using the Voellmy-fluid friction relation and starting the flow as a block release. Their typically smaller volumes (hundreds to thousands of m³) and shorter runout distances generally require much higher-resolution DEMs and computational grids (Fig. 4). Furthermore, the location of landslide release has to be chosen much more carefully because the flow direction is often strongly controlled by the local microtopography such as channels and constrictions.

Often, the runout surfaces are – in contrast to channelized debris flows – on pastures or other agricultural land. Consequently, the friction coefficients used in RAMMS::HILLSLOPE are often markedly different from those used for channelized debris flows.

The package RAMMS::HILLSLOPE currently uses the capabilities of RAMMS::DEBRIS FLOW without the input hydrograph (Fig. 3). Additionally, a modified version of the Voellmy friction relation which accounts for friction reduction due to the presence of granular fluctuations (described earlier) is also available. This results in more realistic simulations of on-slope deposits, in some situations. This model is currently in a beta-testing phase (Loup et al., 2012) involving a number of engineering offices sponsored by the Federal Office for the Environment (FOEN).

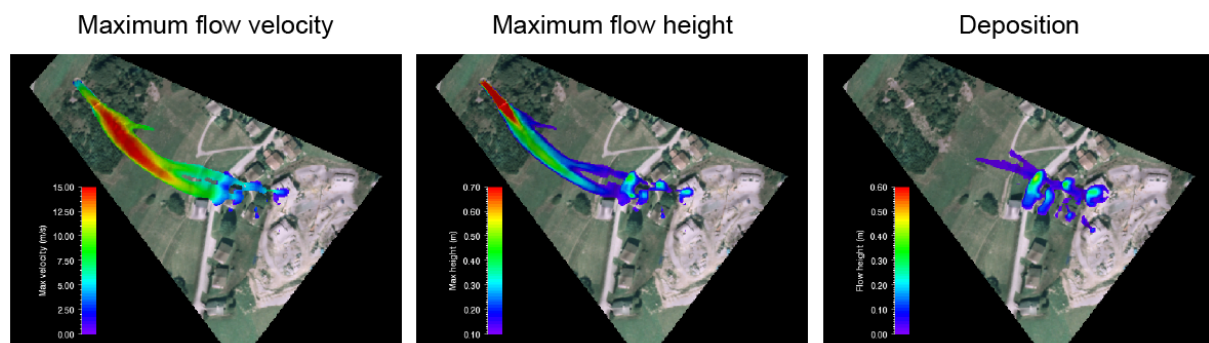

Fig. 4: RAMMS::HILLSLOPE simulation (Acletta, Switzerland) depicting maximum flow velocity, maximum flow height and deposit heights.

RAMMS::ROCKFALL - Rigid body simulation with hard unilateral constraints

Apart from all previously mentioned processes, rockfall is the only process that is not described through flow simulation. Instead rockfall involves a series of impacts and contacts between the terrain surface and the rock body, which result in either sliding, rolling, free fall and bounces or jumps. To model this behaviour requires a different approach to the simulation of flows. The RAMMS::ROCKFALL module employs rigid body algorithms to model the runout dynamics of single rock blocks over three dimensional terrain. This simulation model is currently being developed at the Center of Mechanics (Institute for Mechanical Systems, ETH Zurich) in close cooperation with SLF/WSL. The rock is modelled as a three-dimensional indestructible polyhedral rigid body which can come into frictional contact with a tessellated surface. Concepts from the field of Nonsmooth Dynamics (Glocker, 2001; Leine & Nijmeijer 2004) are used to combine the rigid-body approach with a ‘hard’ modelling of contacts, i.e. hard unilateral constraints expressed by Signorini’s impenetrability condition and Coulomb’s dry friction law. The penalty method, which is often used to predict rockfall runout, introduces a non-physical compliance in the contact and yields stiff differential equations among other drawbacks. In contrast, the ‘hard’ modelling of contacts, being used in RAMMS::ROCKFALL, gives a proper description of contact behaviour, uses fewer parameters and leads to a consistent mathematical formulation.

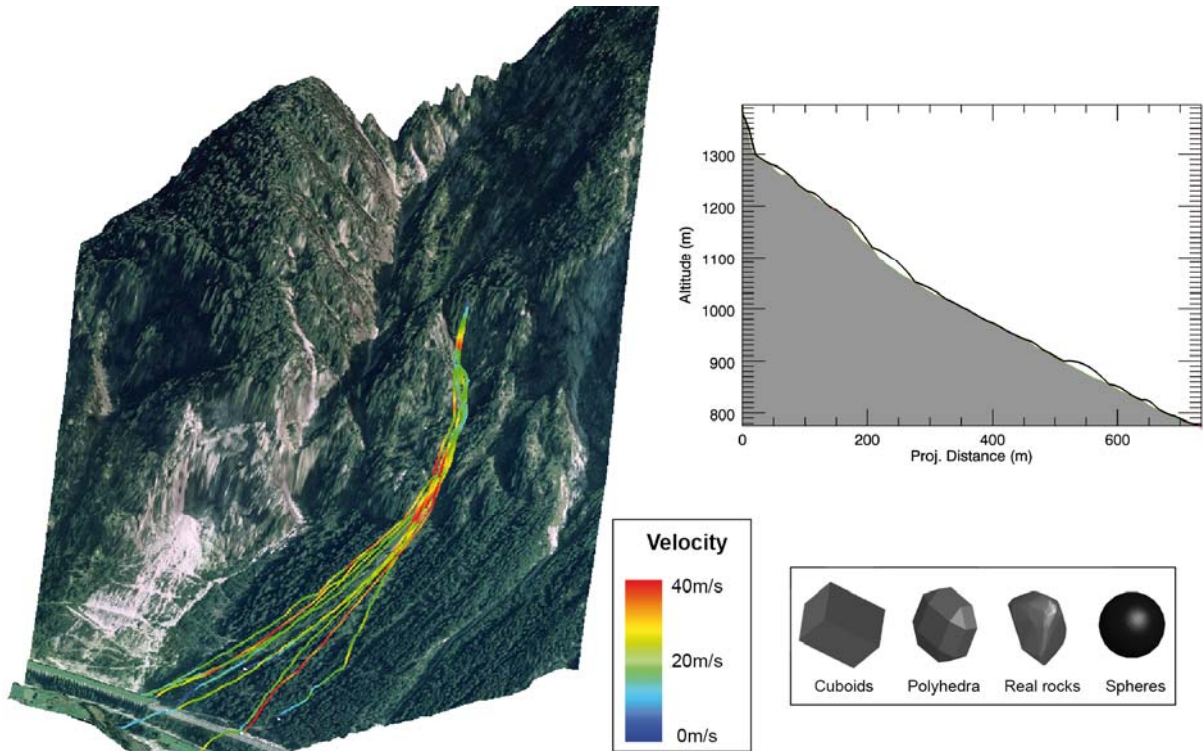

Fig. 5: RAMMS::ROCKFALL simulation using different rock shapes (below right) of a rockfall in Gurtellen (UR) Switzerland displaying velocities (left); trajectory profile plot showing rock jump heights (upper right).

The simulation model describes the rock geometry using three-dimensional convex polytopes. With this arbitrary forms can be simulated such as cuboids, polyhedra, spheres and natural rock forms (Fig. 5). Real rocks are captured using point cloud data taken from natural rocks using laser-scanning techniques and processed into convex polytopes for use in the simulation model. The full three-dimensional simulation of rockfall allows investigation of the influence of rock geometry on the runout distance and dispersion typical of rockfall trajectories in the field (Fig. 5). The height map is bilinearly interpolated to generate a smooth surface for the contact detection between rock and terrain. The contact points are found by ray-casting the vertices of the rock polytope onto the interpolated height-map. The contact geometry between rock and landscape is modelled as a finite collection of discrete contact points. The contact model is a combination of Signorini's law, Coulomb friction law and a (generalized) Newton-type impact law. Indeed there are other sources of dissipation associated with rockfall motion such as rolling friction and the interaction with forests, these are currently being investigated.

The rigid-body modelling approach applied is based on integration techniques for systems with unilateral constraints which are the event-driven integration method and the timestepping method (Acary & Brogliato, 2008; Moreau 1988; Leine & Nijmeijer, 2004; Studer et al., 2008), being far more robust than the former method (Leine & Nijmeijer, 2004). Time-stepping methods, which have been introduced by Moreau (1988), are based on using a time-discretization of generalized positions and velocities, usually with a fixed step size. Integrals of forces over each time step are used instead of the instantaneous values of the forces. The time-stepping method makes no distinction between impulsive forces (due to impacts) and finite forces. Only increments of the positions and velocities are computed, whereas the acceleration is not computed by the algorithm, because it becomes infinite for impulsive forces. The positions and velocities at the end of the time step are found by solving an algebraic inclusion which describes the contact problem, for instance by formulating it as a (Non)linear Complementarity Problem or as a set of nonlinear equations by using the proximal-point function (the so-called Augmented Lagrangian approach) (Alart & Curnier, 1991; Leine & Nijmeijer, 2004). Multiple events may take place during one time step, and the algorithm computes the overall integral of the forces over this time step, which is finite. The time-stepping method is especially useful when one is interested in the global motion of systems with many contact points, leading to a large number

of events. Each individual event is for those applications not of importance but the global motion is determined by the sum of all events. The benefit of time-stepping methods over event-driven integration methods is the fact that no (or less) event-detection and index sets are needed. This makes the algorithm less complex, more robust and will give a reduction in computation time when many contacts are involved. A second advantage of the time-stepping method is its capability to pass accumulation points of impacts. A notable disadvantage of the time-stepping method is its low-order accuracy. Moreau's time-stepping method is used for the numerical time-integration in RAMMS::ROCKFALL. The contact problem in each time step is formulated as a set of implicit equations by using the proximal point function and solved by a Gauss-Seidel iteration method (Alart & Curnier, 1991).

This is an important step for rockfall modelling as it permits a true description of the constellation between the rock body and the ground prior to impact, and avoids the requirement of probabilistically forcing terrain model variations to account for the variability of rockfall trajectories. Instead a variation around given release kinematics allows for the statistical variability in rockfall trajectory required by engineers for rockfall hazard assessment. In doing so, more detailed information of rock mass character are included in simulations, such as the natural variability of the orientation of discontinuities responsible for detachment rock blocks, in addition to the particle size and shape distributions of rock blocks that are held in hazardous rock masses.

CONCLUSIONS

A unified simulation tool can serve a valuable purpose in natural hazards practice and research. However, the tool must supply users with:

1. State-of-the-art, well calibrated and tested process models with stable numerical solution algorithms. The process models should reach a high degree of reliability to ensure continuity of results in practice.
2. Flexible user-input features that facilitate the construction of realistic hazard scenarios. The input features must be specially designed for each process.
3. Two- and three-dimensional output routines coupled with georeferenced maps and photographs to visualize the numerical results.
4. Manuals, handbooks and other user support features should be clear and allow users to solve immediate application problems.

RAMMS was engineered to fulfill these criteria and support natural hazards practitioners in their work. It should be viewed as an additional tool with the potential to enhance the quality of a hazard evaluation and mitigation and perhaps reduce the time required for hazard analysis. Such work requires field investigations by experienced practitioners to evaluate the plausibility of model results in projects concerning public safety.

RAMMS offers a physical based process-simulation tool that meets the needs of the practitioners. Like all natural hazard simulation tools, the results of any given module must be scrutinized by an expert and the results have to be checked for plausibility by using independent methods (e.g. empirical relations) and by field inspections, if possible. The combination of different processes (e.g. avalanches, debris flows and rockfalls) in one user interface results in a major advantage for the user: they only need to learn how to run one program instead of many dissimilar tools, thereby reducing the training time and the potential for errors.

ACKNOWLEDGEMENTS

The project "Multi-body Dynamics of Polygonised 3D Objects with Unilateral Frictional Contact: Application to Rockfall", being a cooperation between the SLF/WSL and the Centre of Mechanics (ETH Zurich), has been funded by the Swiss National Science Foundation under project number #200021-119613/1. We thank FOEN for sponsoring the development of the RAMMS::Hillslope

model. Additionally, we are grateful for the feedback received from the many RAMMS users, which has significantly enhanced the development of this unified natural hazards software environment.

REFERENCES

- Acary V., Brogliato B. (2008) Numerical Methods for Nonsmooth Dynamical Systems; Applications in Mechanics and Electronics, vol. 35 of Lecture Notes in Applied and Computational Mechanics. Springer, Berlin.
- Alart P., Curnier, A. (1991) A mixed formulation for frictional contact problems prone to Newton like solution methods. *Computer Methods in Applied Mechanics and Engineering* 92, 353–375.
- Ammann W. (1999). A new Swiss test-site for avalanche experiments in the Vallée de la Sionne / Valais, *Cold Regions Science and Technology* 30, 3–11.
- Bartelt P., Bühler Y., Buser O., Christen M. and Meier L. (2012). Modeling mass-dependent flow regime transitions to predict the stopping and depositional behavior of snow avalanches. *J. Geophys. Res.*, 117, doi: 10.1029/2010JF001957.
- Berger, C. McArdell, B.W. and Schlunegger, F. (2011). Direct measurement of channel erosion by debris flows, Illgraben, Switzerland. *J. Geophys. Res.*, 116.
- Berger C., McArdell B. and Lauber G. (2012). Murgangmodellierung im Illgraben, Schweiz, mit dem numerischen 2D-Modell RAMMS. Murgangmodellierung in der Praxis. 12th Congress INTERPRAEVENT 2012 – Grenoble / France, Conference Proceedings.
- Bugnion L., McArdell B., Bartelt P. and Wendeler C. (2011). Measurements of hillslope debris flow impact pressure on obstacles. *Landslides*, DOI 10.1007/s10346-011-0294-4.
- Bühler Y., Christen M., Kowalski J. and Bartelt P. (2011) Sensitivity of snow avalanche simulations to digital elevation model quality and resolution. *Ann. Glaciol.*, 52(58), 72–80.
- Bühler, Y., Marty, M. and Ginzler, Ch. (2012). High resolution DEM generation in high-alpine terrain using airborne remote sensing techniques. *Transactions in GIS* (in press).
- Christen, M., P. Bartelt and J. Kowalski. (2010a). Back calculation of the In den Arelen avalanche with RAMMS: interpretation. *Ann. Glaciol.*, 51(54), 161–168.
- Christen, M., J. Kowalski and P. Bartelt. (2010b). RAMMS: numerical simulation of dense snow avalanches in three-dimensional terrain. *Cold Reg. Sci. Technol.*, 63(1–2), 1–14.
- Gerber, W. (2001). Richtlinie über die Typenprüfung von Schutznetzen gegen Steinschlag, Tech. rep., Bundesamt für Umwelt, Wald und Landschaft (BUWAL), Eidgenössische Forschungsanstalt WSL, Bern.
- Glocker Ch. (2001) Set-Valued Force Laws, Dynamics of Non-Smooth Systems, vol. 1 of Lecture Notes in Applied Mechanics. Springer-Verlag, Berlin.
- Glover, J., Volkwein, A., Dufour, F., Denk, M., and Roth, A. (2010). Rockfall attenuator and hybrid drape systems – design and testing considerations, in: *Third Euro-Mediterranean Symposium on Advances in Geomaterials and Structures*, edited by: Darve, F., Doghri, I., El Fatmi, R., Hassis, H., and Zenzri, H., 379–384, Djerba.
- Graf Ch. and McArdell B. (2008). Simulation of debris flow runout before and after construction of mitigation measures: an example from the Swiss Alps. *Proceedings of the International Conference on DEBRIS FLOWS: Disasters, Risk, Forecast, Protection*. Pyatigorsk, Russia, 22-29 September 2008, 233-236.
- Graf, C. and B.W. McArdell (2011). Debris-flow monitoring and debris-flow runout modelling before and after construction of mitigation measures: an example from an instable zone in the Southern Swiss Alps. In: Lambiel C.; Reynard E.; Scapozza, C. (eds) *La géomorphologie alpine: entre patrimoine et contrainte*. Actes du colloque de la Société Suisse de Géomorphologie, 3-5 septembre 2009, Olivone. *Géovisions* no 36. Lausanne, Université de Lausanne Institut de Géographie. 245-258
- Gruber, U. and P. Bartelt. (2007). Snow avalanche hazard modelling of large areas using shallow water numerical methods and GIS. *Environ. Model. Softw.*, 22(10), 1472–1481.
- Jörg P., Granig M., Bühler Y. and Schreiber H. (2012). Comparison of measured and simulated snow avalanche velocities. 12th Congress INTERPRAEVENT 2012 – Grenoble / France, Conference Proceedings.
- Leine R.I., Nijmeijer H. (2004) Dynamics and Bifurcations of Non-Smooth Mechanical Systems,

Lecture Notes in Applied and Computational Mechanics Vol. 18, Berlin Heidelberg New-York, Springer-Verlag.

Loup B., Egli T., Stucki M., Bartelt P., McArdell B. and Baumann R. (2012). Impact pressures of hillslope debris flows. Back-calculation and simulation (RAMMS). 12th Congress INTERPRAEVENT 2012 – Grenoble / France, Conference Proceedings.

McArdell B., Bartelt P. and Kowalski J. (2007). Field observations of basal forces and fluid pore pressure in a debris flow. *Geophysical Research Letters*, VOL. 34, L07406, doi:10.1029/2006GL029183.

Moreau J. J. (1988) Unilateral contact and dry friction in finite freedom dynamics. In *Non-Smooth Mechanics and Applications*, J. J. Moreau and P. D. Panagiotopoulos, Eds., vol. 302 of CISM Courses and Lectures. Springer, Wien, pp. 1–82.

Salm, B., Burkard, A., Gubler, H., 1990. Berechnung von Fließlawinen: eine Anleitung für Praktiker mit Beispielen. Mitteilung 47, Eidg. Institut für Schnee- und Lawinenforschung SLF.

Scheuner, Th., Schwab, S., McArdell, B. (2011) Application of a two-dimensional numerical model in risk and hazard assessment in Switzerland. In 5th DFHM, Padua, Italy.

Schürch, P.; Densmore, A.; Rosser, N. & McArdell, B. (2011). Dynamic controls on erosion and deposition on debris-flow fans. *Geology*, 39, 827-830

Studer C., Leine R.I., Glocker Ch. (2008) Step size adjustment and extrapolation for time stepping schemes in nonsmooth dynamics, *International Journal for Numerical Methods in Engineering*, Vol. 76, No. 11, pp. 1747-1781.

Varnes D. J.: Slope movement types and processes. In: Schuster R. L. & Krizek R. J. Ed., *Landslides, analysis and control*. Transportation Research Board Sp. Rep. No. 176, Nat. Acad. of Sciences, pp. 11–33, 1978.

Voellmy, A. 1955. Über die Zerstörungskraft von Lawinen. *Schweiz. Bauztg.*, 73(12), 159–162.

Volkwein, A., Schellenberg, K., Labiouse, V., Agliardi, F., Berger, F., Bourrier, F., Dorren, L.K.A., Gerber, W. and Jaboyedoff, M. (2011). Rockfall characterisation and structural protection - A review. *Natural Hazards and Earth System Science*, 11, 2617-2651.